

Introduction to Computer Science

Quiz1

A. Single Choice Questions (3%, 45%)

1. The _____ model is the basis for today's computers.

- (A) Leibnitz (B) von Neumann (C) Pascal (D) Charles Babbage

Correct Answer: (B)

The *Turing model* (圖靈模型) is a better model for a general-purpose computer

▶ A *program* is a set of instructions that tells the computer what to do with data

The *output data* now depends on the combination of the *input data* and the program

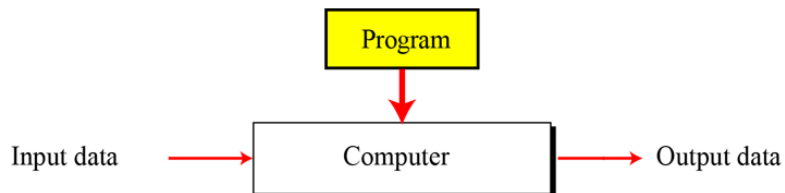

2. According to the von Neumann model, _____ are stored in memory.

- (A) only data (B) only programs (C) data and programs (D) neither data nor programs

Correct Answer (C)

Computers built on the universal Turing machine store data in their memory

▶ John von Neumann proposed that, since programs and data are logically the same, programs should also be stored in the memory of a computer

Computers built on the von Neumann model divide the computer hardware into four subsystems

▶ *Memory, arithmetic logic unit, control unit, and input/output*

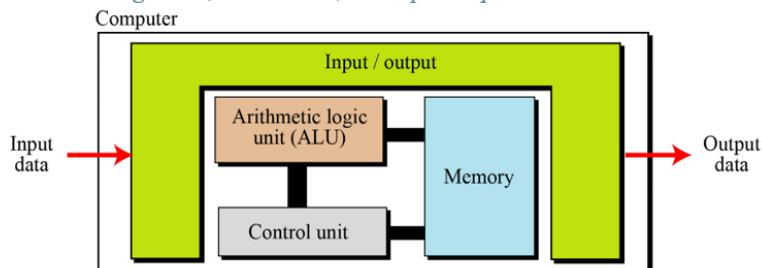

3. Which of the following representations is erroneous?

(A) $(10111)_2$ (B) $(349)_8$ (C) $(3AB)_{16}$ (D) 256

Correct Answer: (B)

In a positional number system, the position a symbol occupies in the number determines the value it represents

► In this system, a number is represented as:

$$\pm(S_{k-1} \dots S_2 S_1 S_0 \cdot S_{-1} S_{-2} \dots S_{-L})_b$$

has the value of

$$n = \pm S_{k-1} \times b^{k-1} + \dots + S_1 \times b^1 + S_0 \times b^0 + S_{-1} \times b^{-1} + \dots + S_{-L} \times b^{-L}$$

in which S is the set of symbols, b is the *base* (基底) (or *radix*) which is equal to the total number of the symbols in the set S

4. Which of the following is equivalent to 24 in decimal?

(A) $(11000)_2$ (B) $(1A)_{16}$ (C) $(31)_8$ (D) None of the above

Correct Answer: (A)

$$(11000)_2 = 24$$

$$(1A)_{16} = 26$$

$$(31)_8 = 25$$

5. Select the correct format in which a CPU executes an instruction

(A) Fetch the instruction from memory, decode the bit pattern, perform the action

(B) Decode the bit pattern, fetch the instruction from memory, perform the action

(C) Perform the action, fetch the instruction from memory, decode the bit pattern

(D) There is not particular format in which a CPU executes an instruction, it is random

Correct Answer: (A)

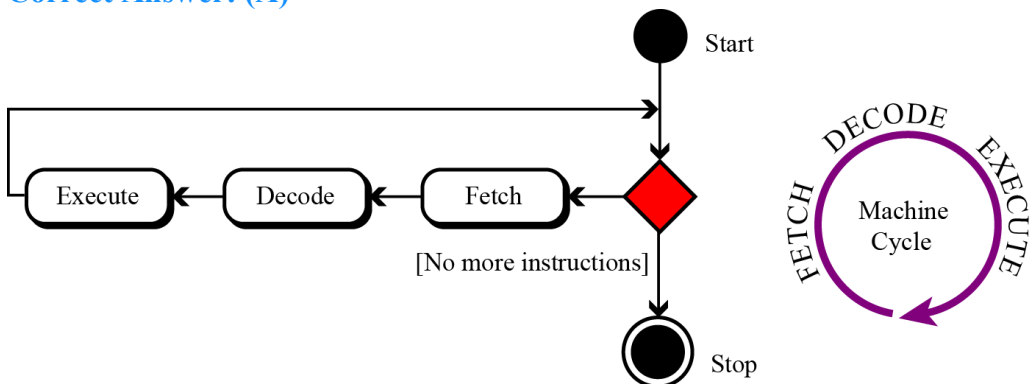

6. Assume a new Excess system uses 17 bits to represent the exponent section. What is the bias value in this system?

(A) 17 (B) 16 (C) 65535 (D) 65536

Correct Answer: (C)

- ▶ In the Excess system, both positive and negative integers are stored as unsigned integers. To represent a positive or negative integer, a positive integer (called a *bias*) is added to each number to shift them uniformly to the non-negative side
- ▶ The value of this bias is $2^{m-1} - 1$, where m is the size of the memory location to store the exponent

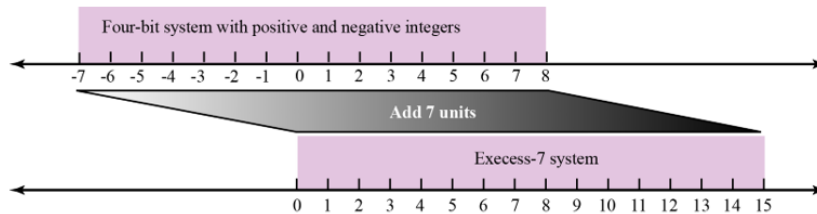

$$2^{17-1} - 1 = 65535$$

7. For an 8-bit allocation, the smallest decimal number that can be represented in two's complement form is _____.

(A) -8 (B) -127 (C) -128 (D) -256

Correct Answer: (C)

Table 3.1 Summary of integer representations

Contents of memory	Unsigned	Sign-and-magnitude	Two's complement
0000	0	0	+0
0001	1	1	+1
0010	2	2	+2
0011	3	3	+3
0100	4	4	+4
0101	5	5	+5
0110	6	6	+6
0111	7	7	+7
1000	8	-0	-8
1001	9	-1	-7
1010	10	-2	-6
1011	11	-3	-5
1100	12	-4	-4
1101	13	-5	-3
1110	14	-6	-2
1111	15	-7	-1

8. To un-set (force to 0) all the bits of a bit pattern, make a mask of all 0s and then _____ the bit pattern and the mask.

(A) AND (B) OR (C) XOR (D) NOT

Correct Answer: (A)

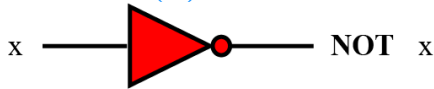

NOT

x	NOT x
0	1
1	0

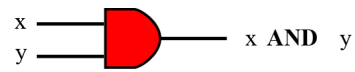

AND

x	y	x AND y
0	0	0
0	1	0
1	0	0
1	1	1

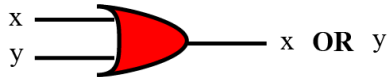

OR

x	y	x OR y
0	0	0
0	1	1
1	0	1
1	1	1

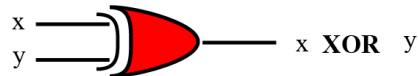

XOR

x	y	x XOR y
0	0	0
0	1	1
1	0	1
1	1	0

9. If the memory address space is 16 MB and the word size is 8 bits, then _____ bits are needed to access each word.

(A) 8 (B) 16 (C) 24 (D) 32

Correct Answer: (C)

- The total number of uniquely identifiable locations in memory is called the *address space*. For example, a memory with 64 kilobytes and a word size of 1 byte has an address space that ranges from 0 to 65,535. The memory units are shown below

Unit	Exact Number of Bytes	Approximation
kilobyte	2^{10} (1024) bytes	10^3 bytes
megabyte	2^{20} (1,048,576) bytes	10^6 bytes
gigabyte	2^{30} (1,073,741,824) bytes	10^9 bytes
terabyte	2^{40} bytes	10^{12} bytes

$$2^4 \times 2^{20} = 2^{24}$$

10. There are _____ bytes in 16 Terabytes.

- (A) 2^{16} (B) 2^{40} (C) 2^{44} (D) 2^{56}

Correct Answer: (C)

$$2^4 \times 2^{40} = 2^{44}$$

11. Which of the following instructions does not fall in the category of arithmetic/logic instructions?

- (A) ROTATE (B) ADDI (C) XOR (D) JUMP

Correct Answer: (D)

12. In the _____ method for synchronizing the operation of the CPU with an I/O device, a large block of data can be passed from an I/O device to memory directly.

- (A) programmed I/O (B) interrupt-driven I/O (C) DMA (D) isolated I/O

Correct Answer: (C)

Subsystem interconnection

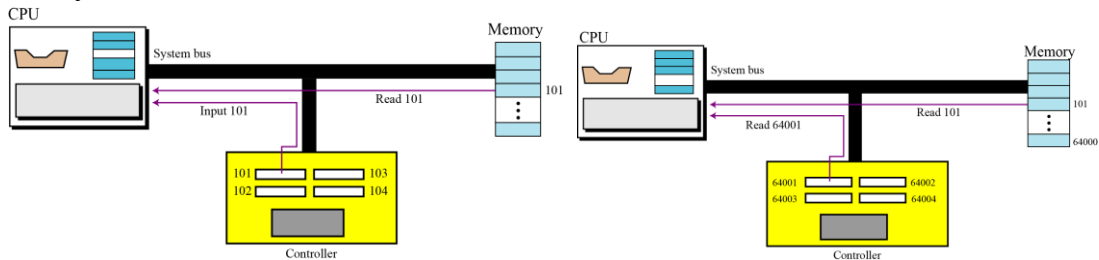

Program execution

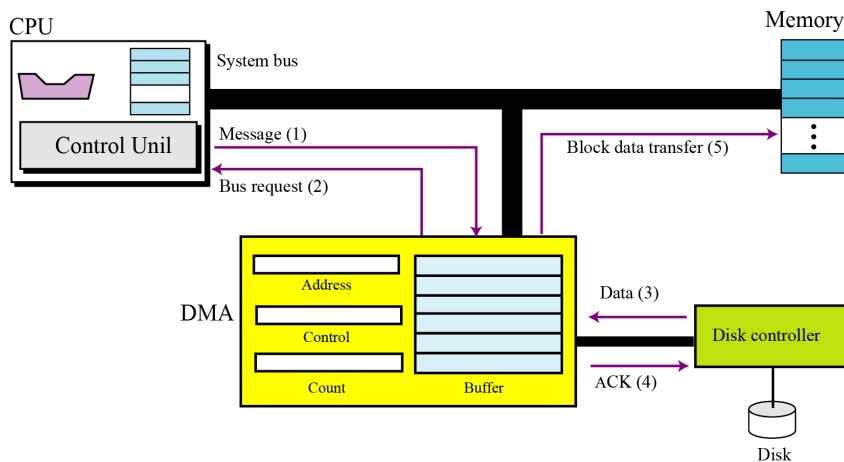

13. The _____ layer of the TCP/IP protocol suite provides services for end users.
 (A) data-link (B) transport (C) application (D) physical

Correct Answer: (C)

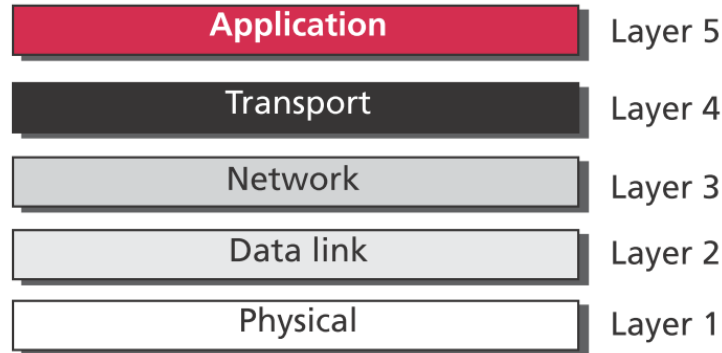

14. _____ is a protocol for file transfer.
 (A) FTP (B) SSH (C) DNS (D) HTTP

Correct Answer: (A)

15. Which of the following statement about the Unicode is not true?
 (A) An extended version of the ASCII (B) It contains 256 characters (C) It is designed to be a superset of ASCII (D) Each character is encoded with 4 bytes

Correct Answer: (B) or (D)

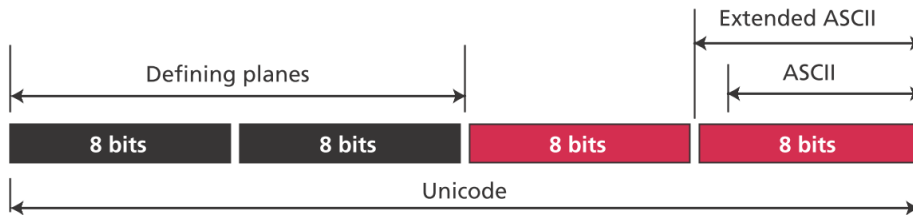

B. Fill-in-the-blank/Short-answer Questions

16. Convert each of the following base 10 representations to its equivalent two's complement representation in which each value is represented in 8 bits:

a. -27

b. 21

Correct Answer: a. 11100101 b. 00010101

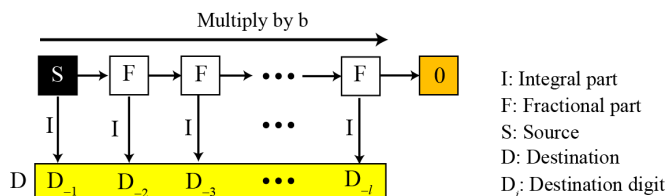
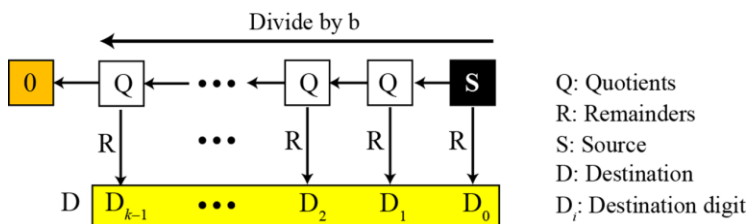

Note:
The fraction may never become zero.
Stop when enough digits have been created.

- a. $27 = 00011011 \rightarrow -27 = 11100101$
b. $21 = 00010101$

17. Convert each of the following binary representations into its equivalent base ten representation

- a. 100.0101
b. 0.1101

Correct Answer: a. $4 \frac{5}{16}$ b. $13/16$

2^{k-1}	2^{k-2}	\dots	2^2	2^1	2^0	Place values
$\pm S_{k-1}$	S_{k-2}	\dots	S_2	S_1	S_0	Number
↓	↓		↓	↓	↓	
$N = \pm S_{k-1} \times 2^{k-1} + S_{k-2} \times 2^{k-2} + \dots + S_2 \times 2^2 + S_1 \times 2^1 + S_0 \times 2^0$						
						Values

18. Perform each of the following additions assuming the bit strings represent values in two's complement notation. Identify each case in which the answer is incorrect because of overflow.

a. $10111 + 11010$

b. $00111 + 01100$

Correct Answer: a. 10001 b. 10011 (incorrect)

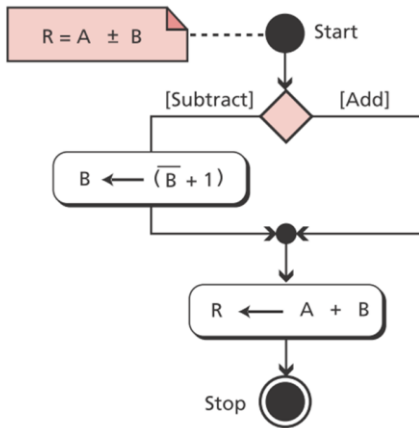
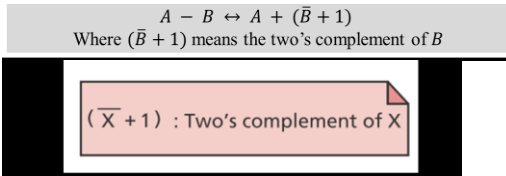

19. Assume that we have a system that is similar to the IEEE standard but only used 8 bit to represent the floating point where the leftmost bit is the sign bit, the following three bit is exponent store in excess_3 system and the final four bit store the mantissa after normalization as follows:

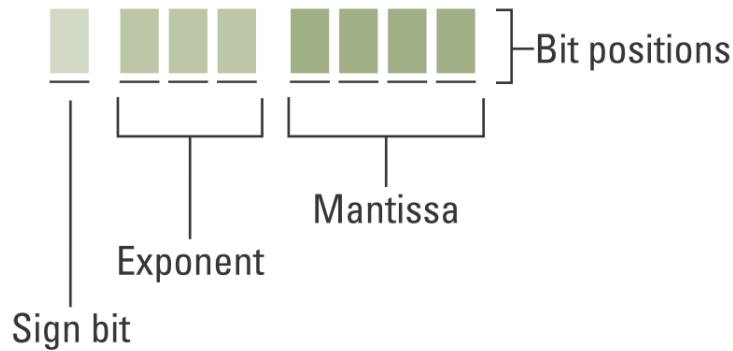

Try to use the above representation to represent

- 6.5
- 9

Correct Answer:

- Store the sign in S (0 or 1)
 - Change the number to binary and normalize
 - Find the values of E and M
 - Concatenate S, E, and M
- 01011010 or 010110100 (Since there is a typo in the original description)
 - 01100010 or 011000100

20. Write the answer to each of the following logic problems.

10101010	10101010	10101010
AND 11110000	OR 11110000	XOR 11110000

Correct Answer: 10100000, 11111010, and 01011010

21. Suppose a digital camera has a storage capacity of 500MB. How many black-and-white photographs could be stored in the camera if each consisted of 512 pixels per row and 512 pixels per column if each pixel required one bit of storage?

Correct Answer: The image consists of $512 \times 512 = 2^{18}$ pixels and therefore $\frac{2^{18}}{8} = 2^{15}$ bytes. This means that about $500 \times \frac{2^{20}}{2^{15}} = 16,000$ images could be stored in the 500 MB camera storage system.

22. Given the following table

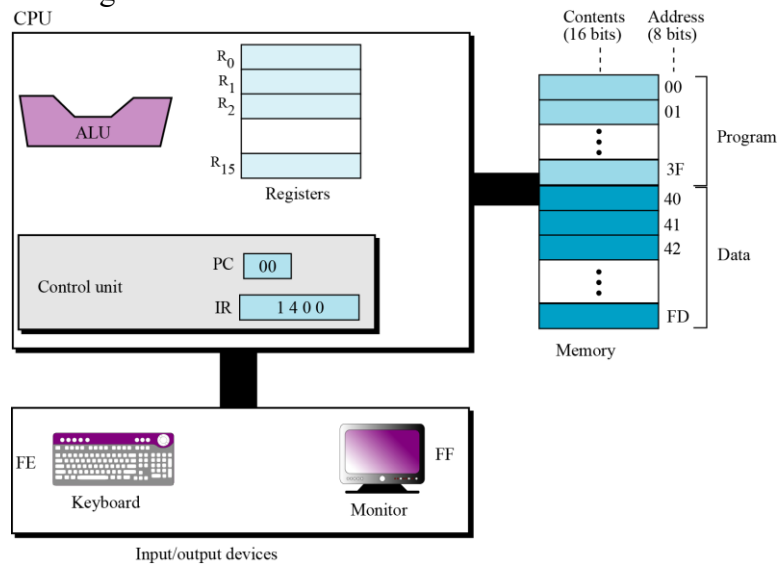

Instruction	Code	Operands			Action
	d_1	d_2	d_3	d_4	
HALT	0				Stops the execution of the program
LOAD	1	R_D	M_S		$R_D \leftarrow M_S$
STORE	2	M_D		R_S	$M_D \leftarrow R_S$
ADDI	3	R_D	R_{S1}	R_{S2}	$R_D \leftarrow R_{S1} + R_{S2}$
ADDF	4	R_D	R_{S1}	R_{S2}	$R_D \leftarrow R_{S1} + R_{S2}$
MOVE	5	R_D	R_S		$R_D \leftarrow R_S$
NOT	6	R_D	R_S		$R_D \leftarrow \bar{R}_S$
AND	7	R_D	R_{S1}	R_{S2}	$R_D \leftarrow R_{S1} \text{ AND } R_{S2}$
OR	8	R_D	R_{S1}	R_{S2}	$R_D \leftarrow R_{S1} \text{ OR } R_{S2}$
XOR	9	R_D	R_{S1}	R_{S2}	$R_D \leftarrow R_{S1} \text{ XOR } R_{S2}$
INC	A	R			$R \leftarrow R + 1$
DEC	B	R			$R \leftarrow R - 1$
ROTATE	C	R	n	0 or 1	$\text{Rot}_n R$
JUMP	D	R	n		IF $R_0 \neq R$ then $\text{PC} = n$, otherwise continue

Key: R_S, R_{S1}, R_{S2} : Hexadecimal address of source registers
 R_D : Hexadecimal address of destination register
 M_S : Hexadecimal address of source memory location
 M_D : Hexadecimal address of destination memory location
 n : Hexadecimal number
 d_1, d_2, d_3, d_4 : First, second, third, and fourth hexadecimal digits

write the code for a program that performs the following calculation:

$$B \leftarrow A - 1$$

A and B are integers in two's complement format. The user types the value of A and the value of B is displayed on the monitor. (Hint: use the decrement instruction.)

Correct Answer: (The address of the register or memory can be changed)

$(1FFE)_{16}$ // $R_F \leftarrow M_{FE}$, Load A from keyboard to R_F

$(240F)_{16}$ // $M_{40} \leftarrow R_F$, Store A in M_{40}

$(1040)_{16}$ // $R_0 \leftarrow M_{40}$, Load A from M_{40} to R_0

$(B000)_{16}$ // $R_0 \leftarrow R_0 - 1$, Decrement A

$(2410)_{16}$ // $M_{41} \leftarrow R_0$, Store results in M_{41}

$(1F41)_{16}$ // $R_F \leftarrow M_{41}$, Load the results to R_F

$(2FFF)_{16}$ // $M_{FF} \leftarrow R_{FF}$, Store the results to be displayed in the monitor

$(0000)_{16}$ // Halt

23. What is the primary difference between using Telnet and SSH to connect to a remote server?

Correct Answer: The SSH protocol encrypts communication to prevent network eavesdroppers from intercepting passwords or other sensitive information.

24. In what way could TCP be considered a better protocol for implementing the transport layer than UDP? In what way could UDP be considered better than TCP?

Correct Answer: TCP actually confirms that the entire message made it to the destination, whereas UDP does not. However, UDP is more efficient.

25. Considering the following URL <https://www.math.nsysu.edu.tw:443/highschool>. Identify which part is protocol, host, port and path, respectively.

Correct Answer:

Protocol: https

Host: www.math.nsysu.edu.tw

Port: 443

Path: highschool